

Center-center dim. X:

Post section:	Post Length:	
	9ft	11ft
2,5" x 12GA	93 1/2"	93 1/2"
2,5" x 14GA	93 1/2"	93 1/2"
3" x 12GA	94"	94"

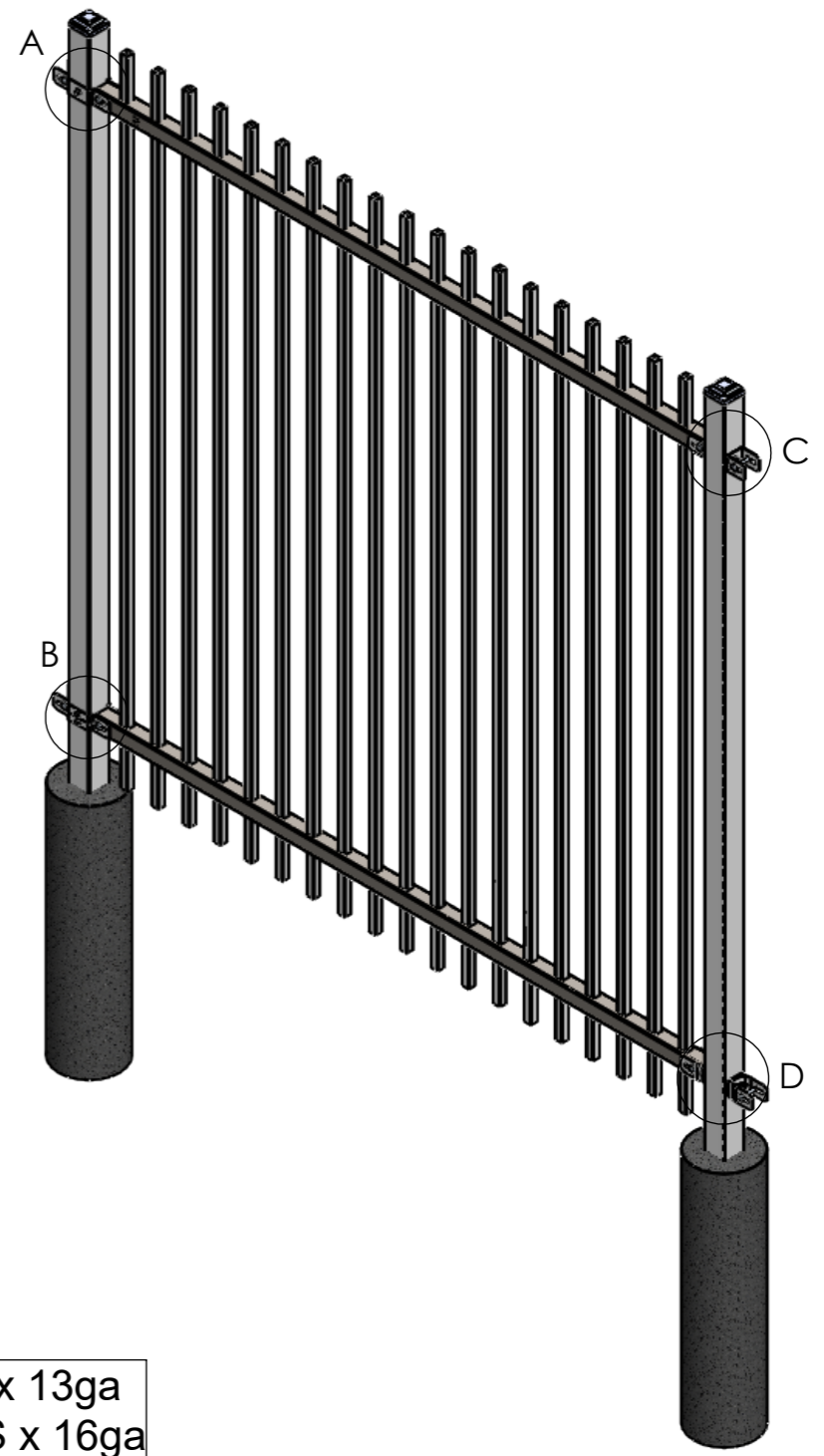

Rail: 2" x 2" x 13ga
Picket: 1" TS x 16ga

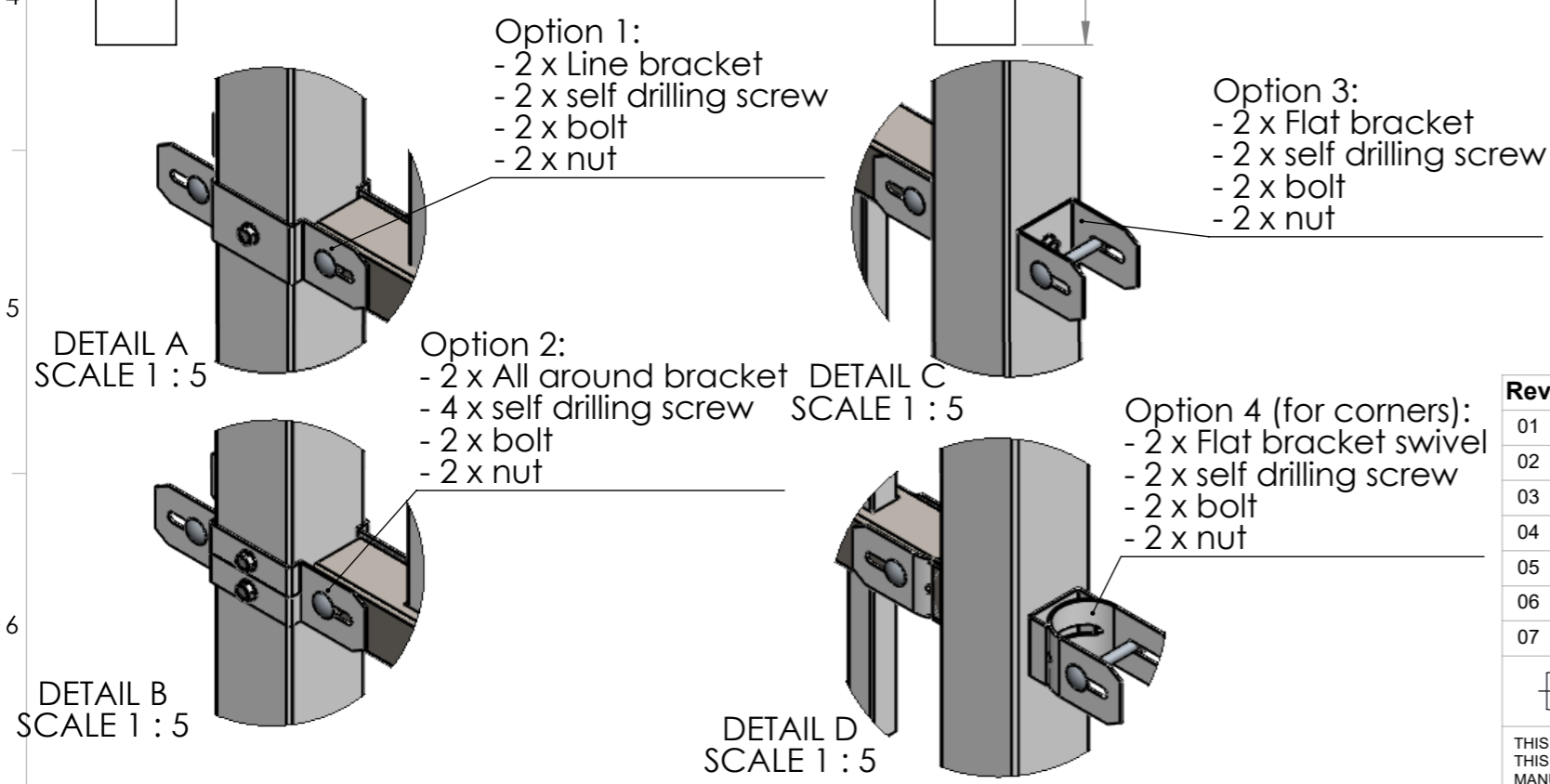

Rev	Date	Changed	By	Material	Mass	Spec
01					102.73 Kg	
02						
03						
04						
05						
06						
07						

UPGRADE INDUSTRIAL SUMMIT
90" X 8FT 2 RAIL

STATUS
Status by

DESIGNER
Designer: Laurein Wylin
Date: 23/03/2021

UPGooA000011

Free form- and placetolerances conform ISO 2768 m
DIN A3
Scale 1:20

THIS DRAWING AND THE RELATED INFORMATION IS AND REMAINS THE EXCLUSIVE PROPERTY OF BETA FENCE. THIS DRAWING AND THE RELATED INFORMATION MAY NEITHER BE COPIED OR REPRODUCED, NOR COMMUNICATED IN ANY WAY TO A THIRD PARTY, NOR USED FOR MANUFACTURING OUTSIDE BETA FENCE. EACH INFRINGEMENT OF THESE INTELLECTUAL PROPERTY RIGHTS OF BETA FENCE SHALL GIVE RISE TO LEGAL PROCEEDINGS.